

Chamber Shrink Wrap Machines

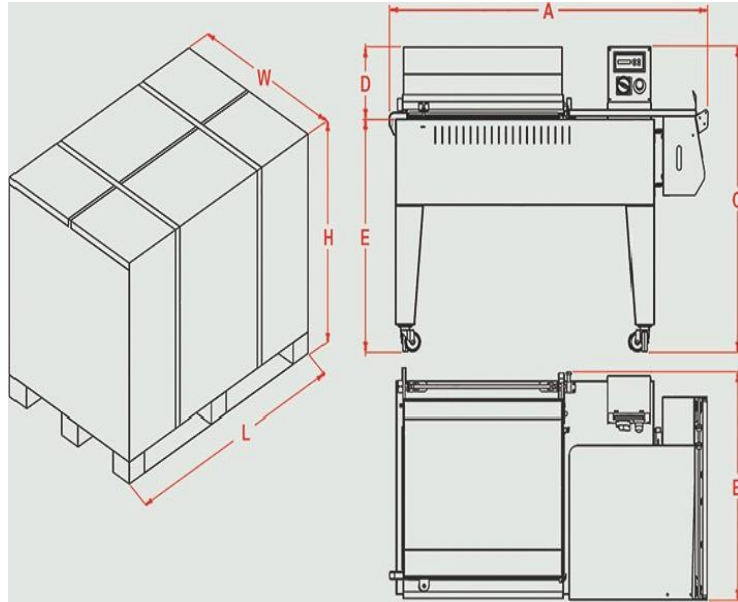

Features

- Seal & shrink single-step application in the same chamber
- Practical and compact solution for low capacity packaging requirements
- Easily transportable on wheels inside a facility
- Timers and temperature controls by digital control panel
- Magnetic holder keeps the chamber hood closed automatically
- Adjustable perforators for air discharge during shrinkage

Interelligent Sealing System & Advantages

- Sealing blade power is generated as much as it is needed
- Adaptive temperature power control during variable cycle times
- Start-up power for the sealing blade is controlled with intelligent system.
- Increased duration of composite blade-supports due to efficient heat control
- Sustainable sealing quality and process accuracy by stabilized heat control

Sealing

- Mechanical switch triggers heating of wire and chamber when the hood is closed
- Sealing is actuated in between wire and silicon rubber by manually closed hood
- Teflon belt covered silicon rubber increase sealing quality and life-span of silicon
- Sealing wire is embedded into heat-resistant composite fiber
- Solid state relays in electrical cabinet helps operating long-term and quietly

Flexibility

- Height adjustable package mesh tray for centre sealing option
- Adjustable power of sealing blade against different film thickness
- Poly-bagging option (without shrink) by switching off the fan
- Temperature, timer other options are controlled with digital system
- Various language options are available in digital control panel
- Service menu is available in digital control panel
- Film roll holder with easy to slide, load and align each package

Packing material

- Working option without pressured air need
- ISO9001 quality standards with the relevant norm's confirmation
- CE certifications, complies with the latest CE directives
- World-wide approved brands for all mechanical and electrical components

Specifications

Model	CSM-4500	CSM-5800	CSM-7000	CSM-8000	For All Model	
Max. Packaging Size W x L x H (mm)	150 x 350 x 150	250 X 450 X 150	350 x 550 x 150	450 x 650 x 150	Max. Capacity	5-10packs / min
Max. Film Width (mm)	400	500	600	700	Max. Roll Diameter (mm)	Ø300 standard
Power	200-240V; 15Ampere; 1 Phase ; 50-60Hz	200-240V; 17Ampere; 1 Phase ; 50-60Hz	400V; 13Ampere; 3 Phase ; 50-60Hz	400V; 17Ampere; 3 Phase ; 50-60Hz	Working Height (E) (mm)	860mm (UT8000-I Series 970)
Consumption (Max./Average)	4Kw / 3Kw	5Kw / 3Kw	6Kw / 4Kw	9Kw / 5Kw	Film Types	POF 7-37micron
Chamber Size (mm)	450 x 300 x 250	580 x 440 x 250	700 x 510 x 250	810 x 610 x 250	PVC	15-25micron
Dimension A x B x C x D (mm)	1080 x 600 x 1140 x 270	1220 x 730 x 1140 x 270	1480 x 860 x 1140 x 270	1840 x 980 x 1220 x 270	Max. Product Height (mm)	150
Pallet Size W x L x H (mm)	800 x 1200 x 770	800 x 1200 x 770	940 x 1590 x 800	980 x 1930 x 1220		
Weight (Kg) Net / Gross	100kg / 130kg	120kg / 150kg	151kg / 205kg	176kg / 224kg		